



FITTING INSTRUCTIONS

Front Wishbone Bushes - 27N (Front Bush), 27P (Rear Bush) & 27Q (Shock Bush)

Step 1:
Remove existing bushes and ensure the bore is clear of debris and sharp edges.

Step 2:
27N (Front Bush) Should be fitted with the flange towards the back of the car as shown in the diagram.

Step 3:
27P (Rear Bush). Apply some washing-up liquid or similar to the leading edge of the bush.

Step 4:
Fit the bush from the bottom to the top as per the markings on the bush. The larger flange should be towards the road.

Step 5:
Rotate the bush until the embossed arrows align with the front bush axis as shown in the diagram.

Step 6:
Insert the square inner tube ensuring the alignment is kept true.

Step 7:
27Q (Shock Bush). Apply washing-up liquid or similar to the leading edge of the bush.

Step 8:
Push the bush in from the front to the rear of the vehicle. The large flange should be towards the front of the vehicle as shown in the diagram.

Step 9:
Refit control arms to vehicle and when at ride height, torque to manufacturers spec .

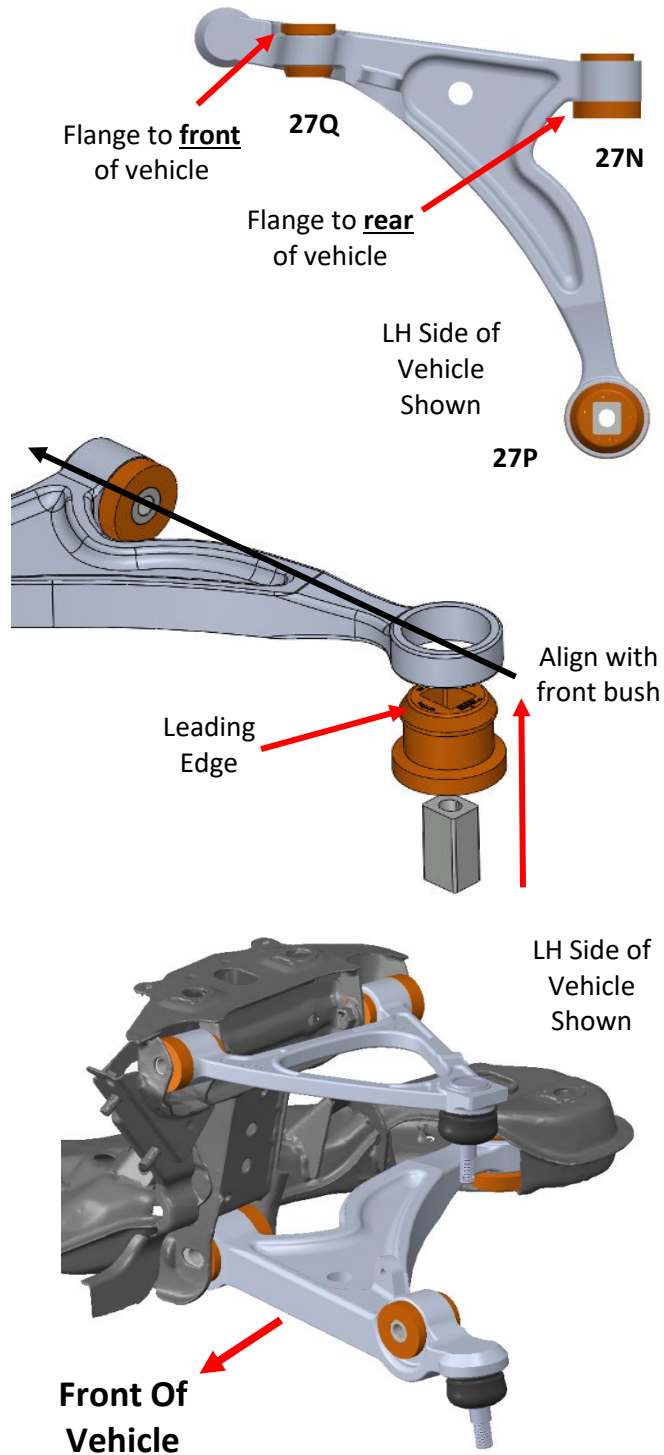

If you have any questions regarding the fitment of these bushes, please give us a ring on 01978 664316 or send us an e-mail at sales@polybush.co.uk.