



FITTING INSTRUCTIONS

55A - Front Wishbone Rear Bush

55A Contains:
2 x Polyurethane Pieces
2 x 7AK Inner Tubes

Step 1:
Remove the existing bushes. Ensure outer sleeve is removed.

Step 2: **IMPORTANT**

Using a file or emery paper, remove any sharp edges from the bore on both edges. Failure to do so can lead to damage of the bush.

Step 3:
Apply washing-up liquid or similar to the bushes leading edge.
Note: This bush is symmetrical and can be fitted either way around.

Step 4:
Press in the bush until fully seated in the bore from the top side of the wishbone.

Step 5:
Insert the inner tube until flush either side of the bush.

Step 6:
Refit wishbone to the vehicle and torque to manufacturers settings.

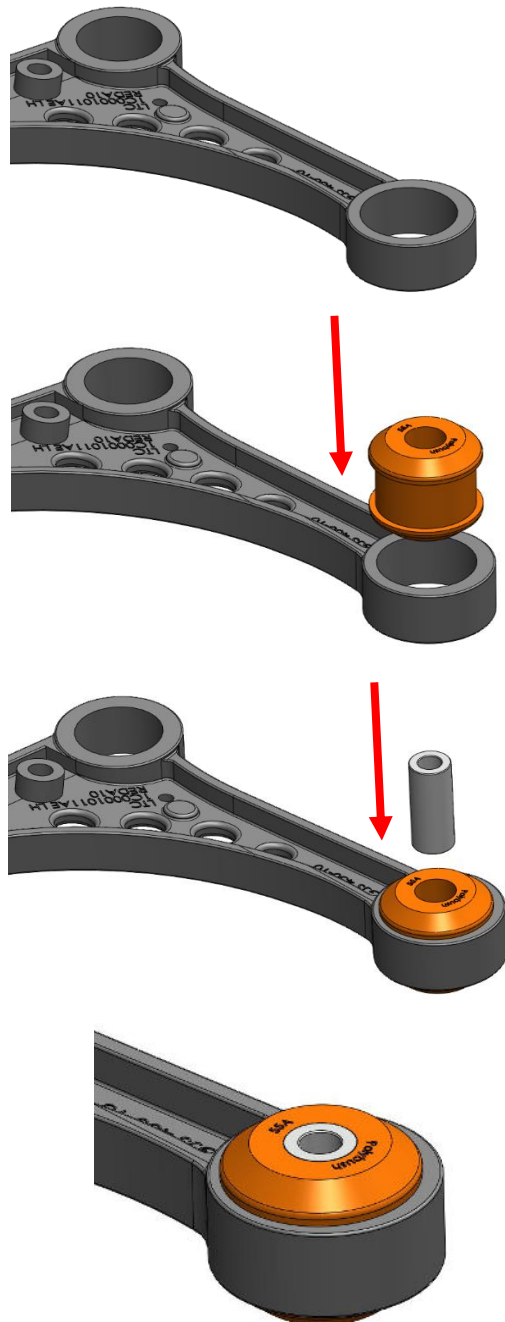

If you have any questions regarding the fitment of these bushes, please give us a ring on 01978 664316 or send an e-mail to sales@polybush.co.uk.