

FITTING INSTRUCTIONS
41AX - Front Upper LH Engine Mount Insert

41AX Contains
1 x Poly Piece
1 x Washer

Step 1:

Remove current engine mount from the vehicle. This will make installing the insert easier.

Step 2:

Cover the insert and existing engine mount in washing-up liquid or similar to aid fitment.

Step 3:

Align the bush with the mount. There is a odd flat face which will match up with a gap in the rubber mount as shown in the diagram.

Step 4:

Using a Vice or similar, push the bush into the mount. This may take several adjustments to ensure the bush is going in flat.

Step 5:

Push the insert until it is near enough flush with the steel inner tube as shown.

Note: The bush will want to raise slightly. This will be clamped down by the washer above.

Step 6:

Do not refit the upper stopper plate (50875-SDA-A11) and instead, fit the supplied washer.

Step 7:

Refit existing bolt and torque to manufacturers settings.

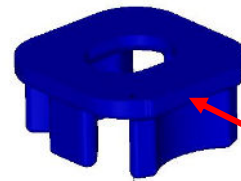
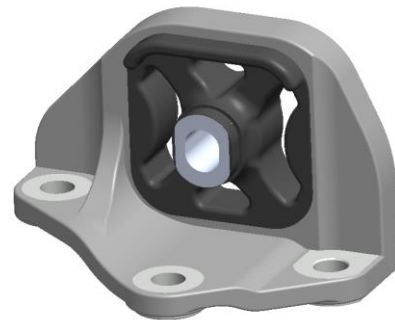

Odd Flat Face

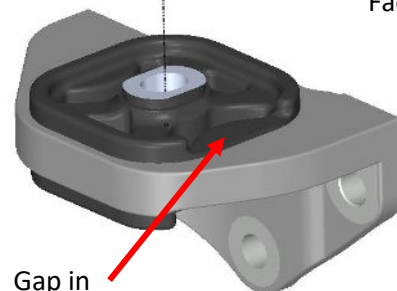

Gap in rubber

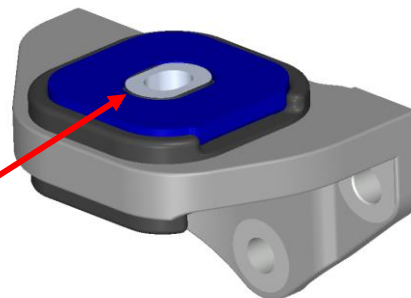

Flush with inner tube

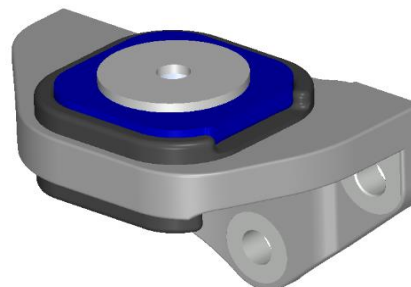

If you have any questions regarding the fitment of this bush, please give us a ring on 01978 664316.

or send an e-mail to sales@polybush.co.uk.