



FITTING INSTRUCTIONS

40DL - Rear Lower Control Arm (Spring Bucket) Inner Bush

40DL Contains
 2 x Poly Pieces
 2 x Inner Tubes
 2 x Outer Tubes



Step 1:

Remove old bush and ensure bore is clean and has no sharp edges. NOTE: OEM bush is tapered, measure both sides and ensure bush is pushed out in the correct direction.

Step 2:

Insert the outer metal into the bore ensuring the smaller end leads first. You should be able to insert the outer tube in more than half way by hand. If not, you have it the wrong way around.

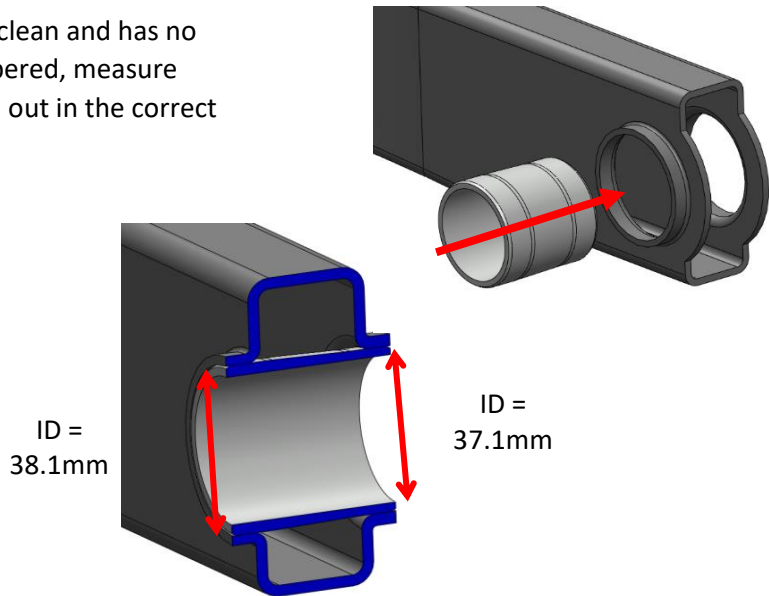

Step 3:

Press the outer metal in until flush with either side of the arm.

Step 4:

Apply some washing-up liquid or similar to the flange of the bush and push into the outer metal until fully seated.

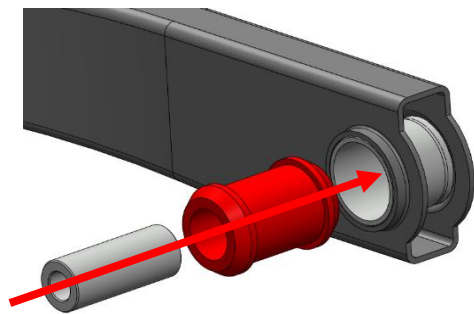

Step 5:

Insert the inner tube until flush with either side of the bush.

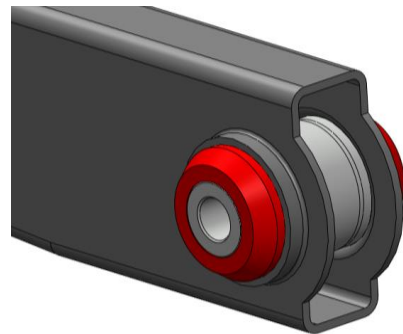

Step 6:

Refit to the vehicle and torque to manufacturers settings.

If you have any questions regarding the fitment of these bushes, please give us a ring on 01978 664316 or send us an e-mail sales@polybush.co.uk