



FITTING INSTRUCTIONS

27A - Front Upper Wishbone Bush

27A Contains:
 4 x Poly Pieces
 Please note: The tubes are bonded into the bushes.



Step 1:
 Remove existing bushes and ensure the bore is clear of debris and sharp edges.

Step 2:
 Apply washing-up liquid or similar to the smaller leading edge of the bush.

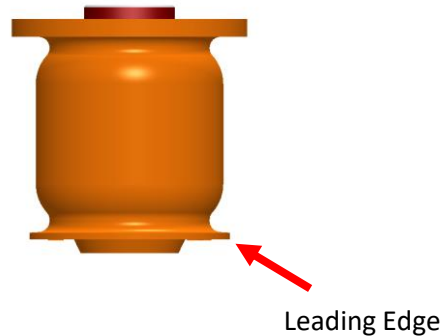

Step 3:
 Insert the bush ensuring the larger flange is on the outside of the wishbone as shown in the diagram.

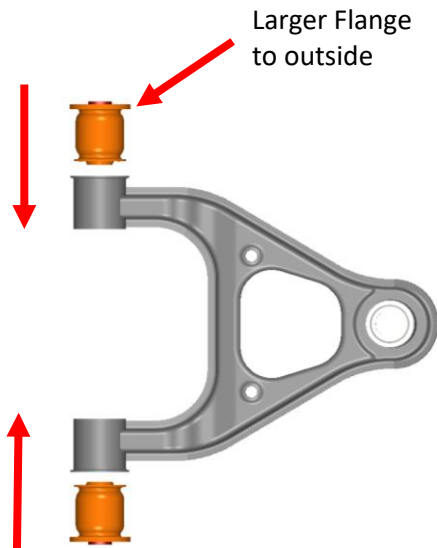

Step 4:
 Repeat for the opposite side.

Step 5:
 Re-fit to the vehicle and leave the nuts finger tight.

Step 6:
 Ensure car is at ride height before tightening to manufactures torque settings.



If you have any questions regarding the fitment of these bushes, please give us a ring on 01978 664316 or send us an e-mail on sales@polybush.co.uk.