



**FITTING INSTRUCTIONS**

44FD - Rear Trialing Arm Bush	
44FD Contains	<b>NOTE:</b> 44FD fits OEM Arm No.s 5Q0-505-223/4-C. This bush will <b>NOT</b> fit Arm No.s 1K0-505-223/4. Please use 44AY bush for this Arm Part No.
2 x 44FD Bushes	
2 x 44AY Inner Tubes	

Step 1: Remove OEM bush from arm.

Step 2: Apply washing-up liquid to the smaller leading flange. (Part No. Side)

Step 3: Insert bush with the small leading flange pushing through the inner radius edge of the arm ensuring the bush is fully seated. (Inside of the car to Outside)

Step 4: Insert the inner tube.

Step 5: Refit the bracketry along with the plastic protective cover. Do **NOT** fully torque the bush at this stage.

Step 6: Refit the arm to the car and tighten to OE torque specifications when at ride height. **NOTE:** Ensure suspension is settled, prior to final torque.

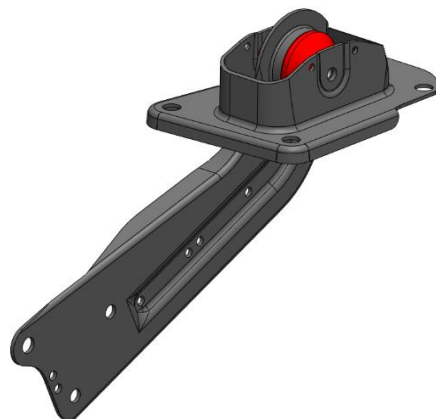
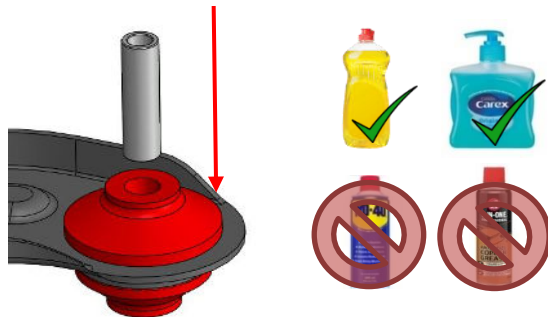
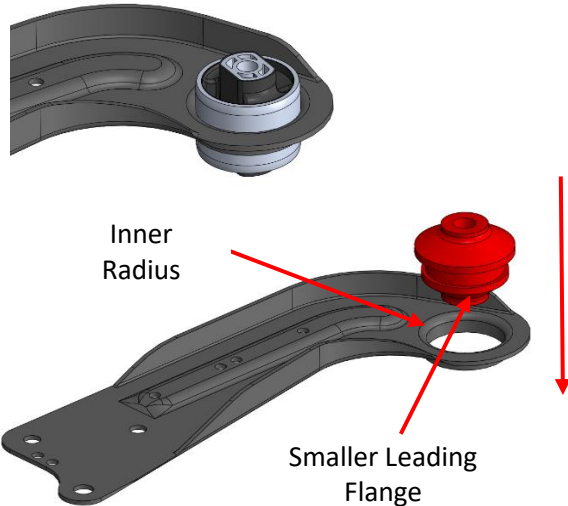

If you have any questions regarding the fitment of these bushes, please give us a ring on 01978 664316.

or send an e-mail to [sales@polybush.co.uk](mailto:sales@polybush.co.uk).