



FITTING INSTRUCTIONS

40DG - Rear Trailing Arm Bush (Volvo Only) (Additional Holes for Exhaust Mount)

- 40DG Contains**
 1 x 40DG LH Bush
 1 x 40DF RH Bush
 2 x Outer Tubes
 4 x M8x10 Hex Head Bolts



Step 1:

Remove old bush and ensure bore is clean and has no sharp edges.

Step 2:

Fit the Outer Metal to the arm pushing from the inside (Radius edge) to outside of the vehicle. Use a Copper/Hide hammer to tap the tube into the arm to ensure it is square. Using a thread bar and the appropriate tools wind the tube into the housing. The tube should sit flush with the outer metal side. See diagram below.

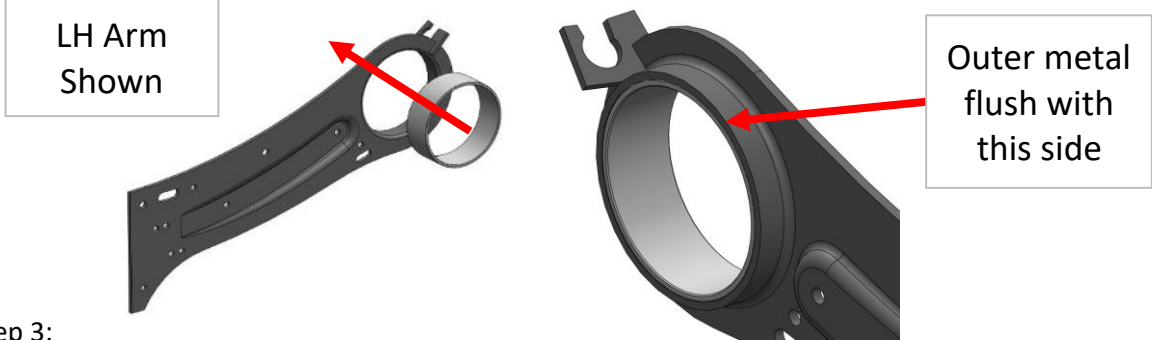

Step 3:

Apply washing up liquid to the outer tube bore and leading edge/bore of the bush.

Step 4:

Press the bush in ensuring the 5 holes are facing to the front of the car in the same direction the outer metal was installed. Do not worry about orientation of the bush at this time. The bush can be rotated after fitting. The bush may try to deflect away when being pressed in. Continue to press the bush in until the flange enters the bore of the tube.

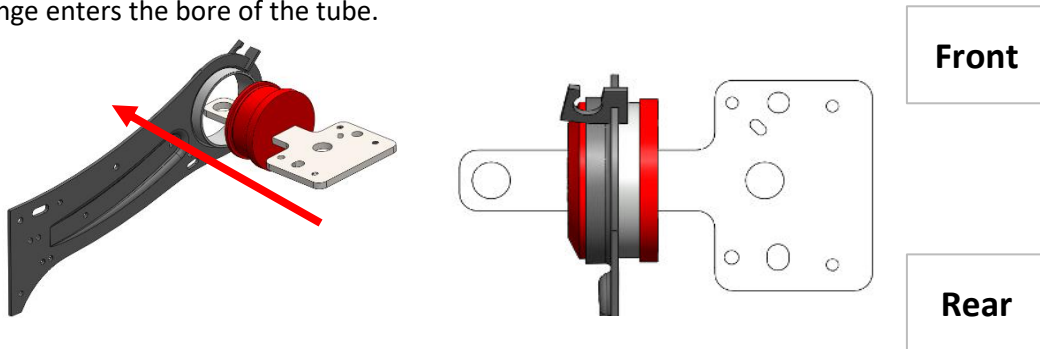

Step 5:

Refit the brake pipe bracket to the metal bracket using the provided M8x10 Hex Head Bolt. This is to be inserted from the underside of the vehicle.

Step 6:

Refit the Exhaust Mount using bolts provided.

Step 7:

Install 40DF in the same manner.

